

## GENERAL INFORMATION

Project Name: \_\_\_\_\_

### STANDARD NSF LISTED FINISH OPTIONS

- Brushed Aluminum       Chrome
- Gloss Black               Wrinkle Black
- Smoked Copper         Polished Brass Finish
- Other \_\_\_\_\_

### GLASS THICKNESS

- 1/4" Tempered Glass (not for shelves)  
Centerline Max 54"
- 3/8" Tempered Glass (for shelf or span more  
than 54") Centerline Max 66"
- 1/2" Tempered Glass (for shelf or span more than  
66") Centerline Max 72"

Maximum span between legs on counter is recommended at 78".

### GLASS CORNERS

- 1" Radius Corner (standard)
- Square Corners

### LIGHT OPTIONS

- 2580      Slimline LED Light
- 790        Stealth Warmer
- 705        Stealth Light & Warmer
- 500        Stealth Heat/Light/Heat Combo

All BSI light and warmer units are UL Listed. See light spec sheets for detailed information. Also available with other manufacturers' light units. Contact BSI for details.

### INSTALLATION OPTIONS

Above Counter

Under Counter

(Requires Under-Counter Reinforcement & Access)

- Surface Installation 720A/726A: Steel Post and Flange w/Flange Cover
- Surface Installation 725A: Cut Flange
- Under-Counter Installation 720A/726A: Steel Post and Flange w/Flange Cover or without Flange Cover
- Under-Counter Installation 725A: Narrow Custom Flange

## ZG9950-2

Double-Sided Mega Span

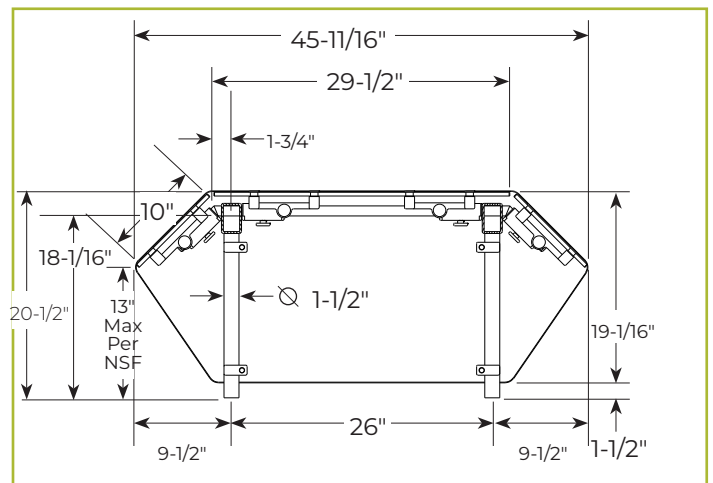

To meet NSF guidelines, end panels are included on all BSI quotations unless specifically excluded. (See End Panel Page for More Details.)